

INTERNATIONAL

# Cruise & Ferry

REVIEW



**Bus-assisted control and monitoring  
of motorised fire dampers on ships  
by Belimo Automation AG**

Reprinted from International Cruise & Ferry Review, Spring/Summer 2005

# Bus-assisted control and monitoring of motorised fire dampers on ships

A cruise liner certainly represents a complex challenge when it comes to implementing safety systems. One of these systems is responsible for controlling and monitoring motorised fire dampers.

A cruise liner is divided into horizontal decks and vertical fire zones. In the event of fire, it is possible to ensure that the spatial extent of the damage will be limited because fire dampers close automatically to seal off the ventilation ducts. This means the smoke and fire is prevented from crossing into adjacent areas and from propagating.

Thermal fuses on the fire dampers are tripped at predefined temperatures, and the damper closes. Built-in limit switches send this information to an automation system. This displays the status of every single fire damper in the ship on screen. Large cruise liners have more than 1,000 of these fire dampers.

Every single damper must be connected to the

automation system by means of an electrical cable. In addition to the supply voltage for the damper actuator, cables are also routed for the damper 'open' and 'closed' position checkback.

To date, these fire dampers have been connected using a star-shaped line topology. This soon adds up to several thousand metres of electrical cables, depending on the size of the AC rooms as well as the number and distance of the dampers.

For this reason, Siemens Building Technologies developed a bus-assisted fire damper control and monitoring system. This system, in combination with Belimo fire damper actuators, represents a fire protection solution offering high levels of safety, flexibility and ease of installation.

Fire dampers are safety systems, therefore only



Source: Belimo Automations AG

**The provisions of SOLAS (Safety of Life at Sea) define the quantity and quality of fire dampers to be fitted in ships**

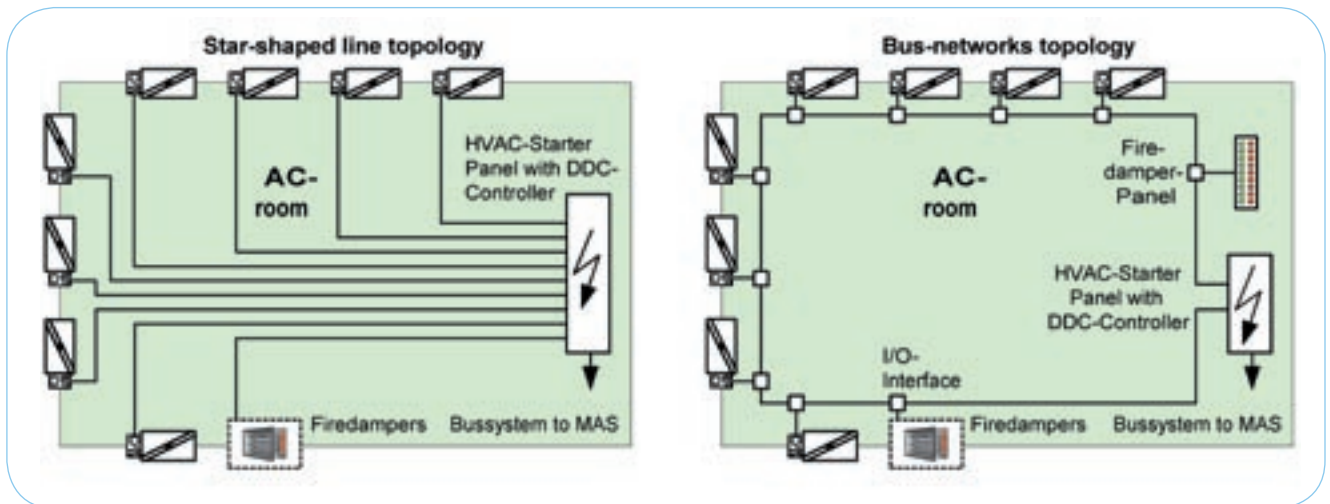

classified components are used (e.g. by Germanischer Lloyd, Lloyds Register of Shipping, ABS and DNV).

The redundant, short circuit-proof ring bus topology significantly minimises the complexity of cabling. The I/O interface boxes contain the connection modules for the ring bus where standard Belimo actuators can be connected directly. Depending on the version, this can be done using conventional terminals or prefabricated, ready-to-connect cables.

This system offers a high degree of flexibility because of its addressable properties. Dampers in different rings can be grouped together into a logical triggering group. The advantage is that there is no need to take account of what group a particular damper belongs to during installation of the system. The logical groups are not formed and functionally linked together until the startup phase at the end of installation. In addition, a ring can easily be expanded up to the design limits of the system.

Central fire damper panels are installed in the AC rooms. All the dampers assigned to the ventilation systems of the AC room send their signals to these particular panels. There is a test switch for each group that enables the stipulated triggering tests to be performed. It is possible to connect relay cards to the fire damper panels using a separate bus line. These cards are used to electronically interlock the ventilators. This measure increases the shut-off safety of the corresponding ventilation system in the event of triggering.

Various methods can be used for central visualisation of the fire dampers. The Hazard

Management System supplied by Siemens makes it possible to have a graphical display of all connected dampers and, in addition, permits targeted operation of individual dampers. The Hazard Management System enables the highest possible levels of safety and comfort to be achieved in operation.

Unidirectional integration into an Integrated Alarm and Monitoring System (IMAS) represents another possibility. In this case, all the status information is sent to the IMAS via a serial interface. Graphical overviews make it possible to localise the messages effortlessly. However, individual dampers cannot be operated using IMAS.

The same principles as for IMAS apply as far as integrating the fire damper monitoring into the HVAC Management System is concerned. This too only permits graphical visualisation of the fire dampers on the system.

In the two latter cases, the individual dampers can then only be operated using the central unit installed in each fire zone.

Thanks to the high levels of safety, flexibility and ease of installation, this system in combination with Belimo actuators offers many advantages for shipbuilding. Furthermore, the significant savings in electrical cables lead to weight reductions and, consequently, lower fuel consumption and lower energy costs. ■

*By Peter Salomon, Vertical Market Marine Solutions, Siemens Building Technologies.*



# More comfort and safety on board.



5  
year warranty  
SWISS QUALITY

> The smart choice.  
[www.belimo.com](http://www.belimo.com)

## Actuators for HVAC applications from the world market leader.

Be it for a luxury liner, a ferry, a freighter or a yacht, Belimo's full range of products offers the leading-edge technology for motorising dampers and valves in heating, ventilating, and air-conditioning systems. Rely on Belimo's above-par advice and service for guaranteed comfort, safety and economy on board!

Headquarters: BELIMO Automation AG, Brunnenbachstrasse 1, 8340 Hinwil/Switzerland  
Telephone: +41 (0)43 843 6111, E-Mail: [info@belimo.ch](mailto:info@belimo.ch)

**BELIMO**<sup>®</sup>